

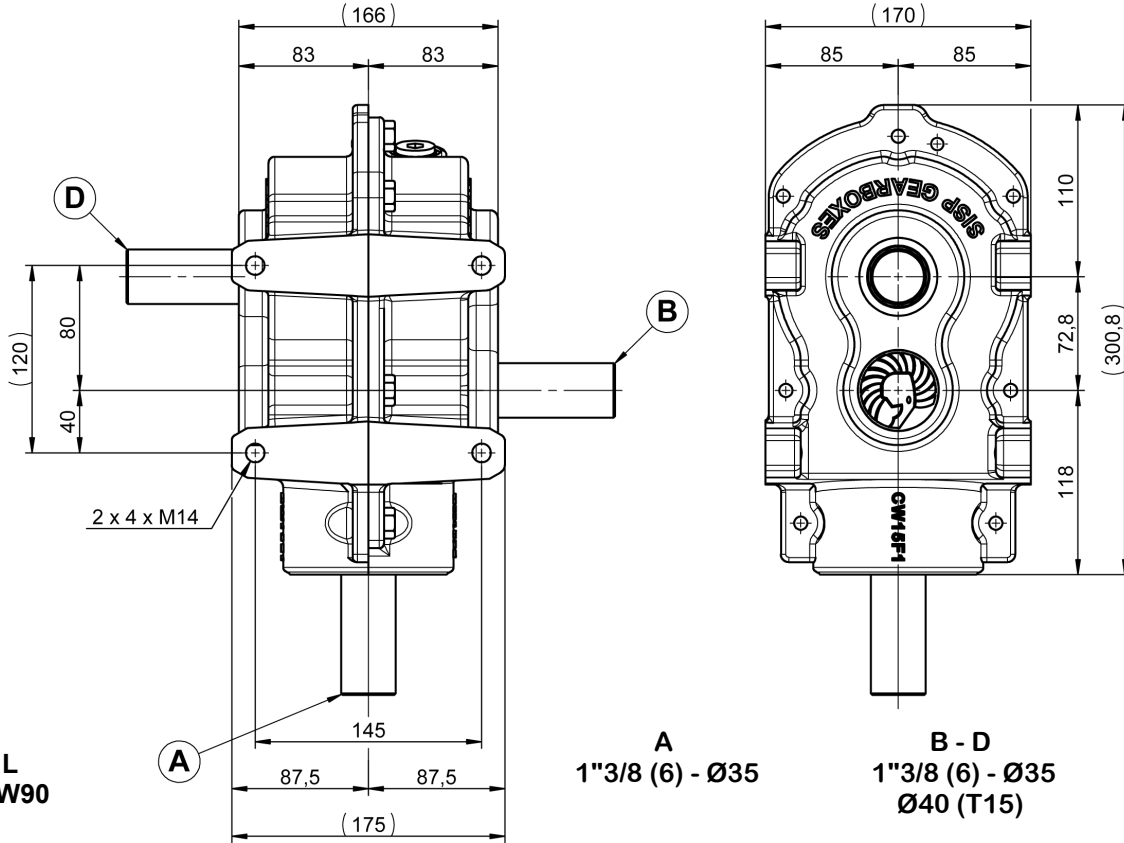

W15 - T15 RENVOI D'ANGLE

W15 - T15 GEARBOX



0.8 L
TM80W90

A
1"3/8 (6) - Ø35

B - D
1"3/8 (6) - Ø35
Ø40 (T15)

26 KG

W15 STANDARD / W15 STANDARD

RAPPORT RATIO	A				B		D		TYPE
	T/MN - RPM	CV - HP	KW	NM	T/MN - RPM	NM	T/MN - RPM	NM	
1/1-1/6	540	30	22	340	540	340	90	410	R1

T15 RENFORCE (TARIERE) / T15 REINFORCED (AUGER)

RAPPORT RATIO	A				B		TYPE
	T/MN - RPM	CV - HP	KW	NM	T/MN - RPM	NM	
1/5	540	30	22	340	108	790	R2
1/5		30	22	340	108	790	R3

