

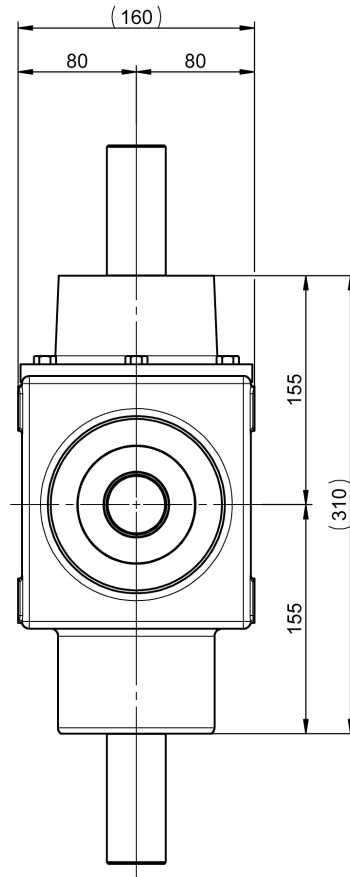

# T50 RENVOI D'ANGLE

## T50 GEARBOX

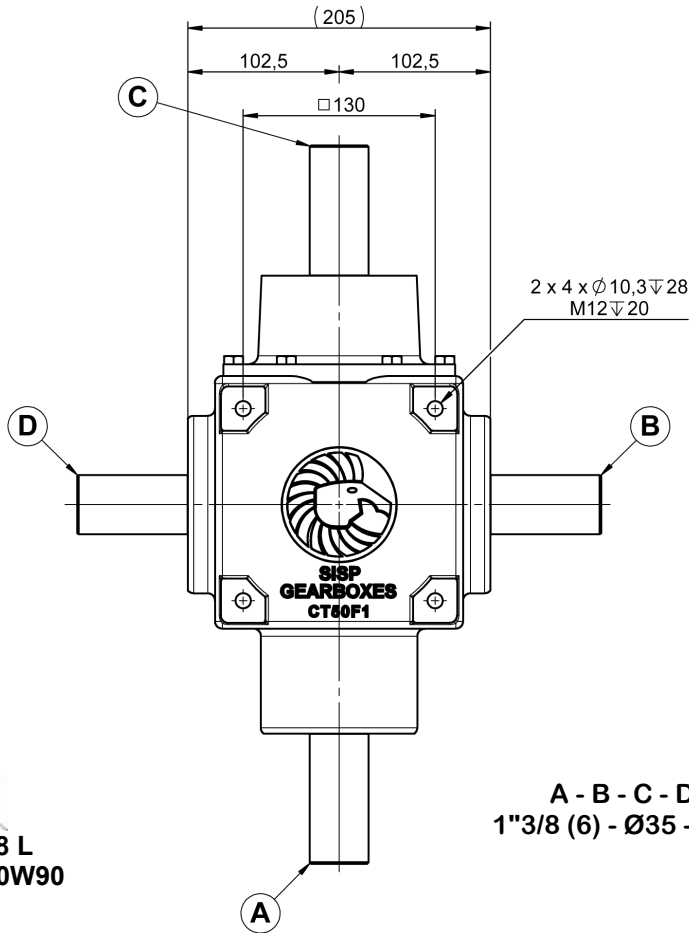

A - B - C - D  
1"3/8 (6) - Ø35 - Ø40

0.8 L  
TM80W90

26 KG

RAPPORT RATIO	T/MN - RPM	A - C			B - D	
		CV - HP	KW	NM	T/MN - RPM	NM
1/1	540	89	65	1180	540	1180
1/1.5		52	38	680	360	1028
1/2.07		39	29	517	260	1070
1/1	1000	152	112	1080	1000	1080
1/1.5		89	65	637	666	956
1/2.07		68	50	487	483	1008

