

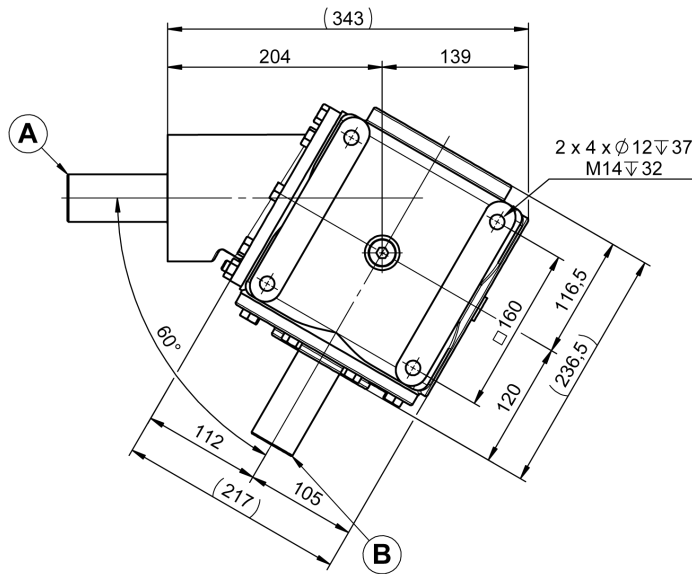

RA202 RENVOI D'ANGLE

RA202 GEARBOX (60° - 120°)

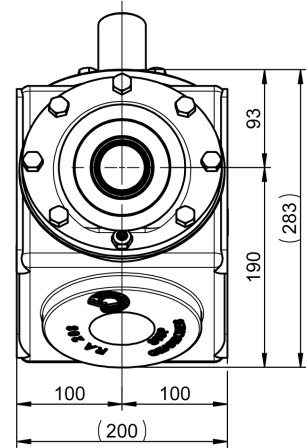
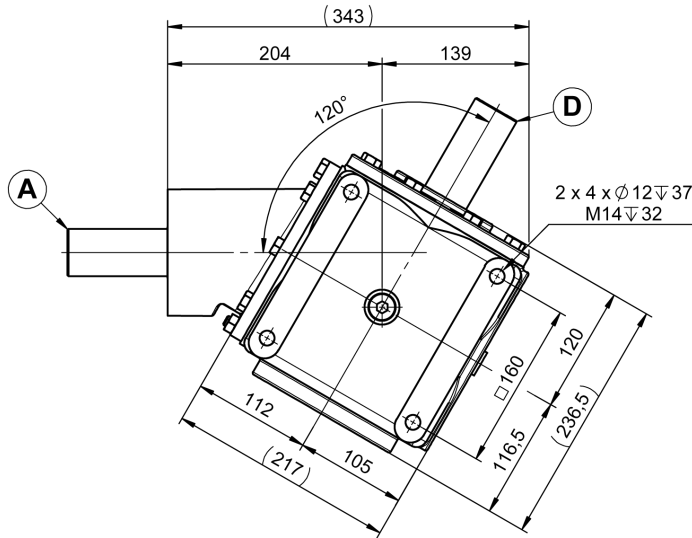

A - B - D
 1"3/8 (6) - 1"3/4 (6)
 Ø45 - Ø45 (16)

1,9 L
 TM80W90

47 KG

RAPPORT RATIO	T/MN - RPM	A			B - D	
		CV - HP	KW	NM	T/MN - RPM	NM
1/1.83	540	101	74	1332	295	2444
1/1.83	1000	174	128	1244	546	2281

