

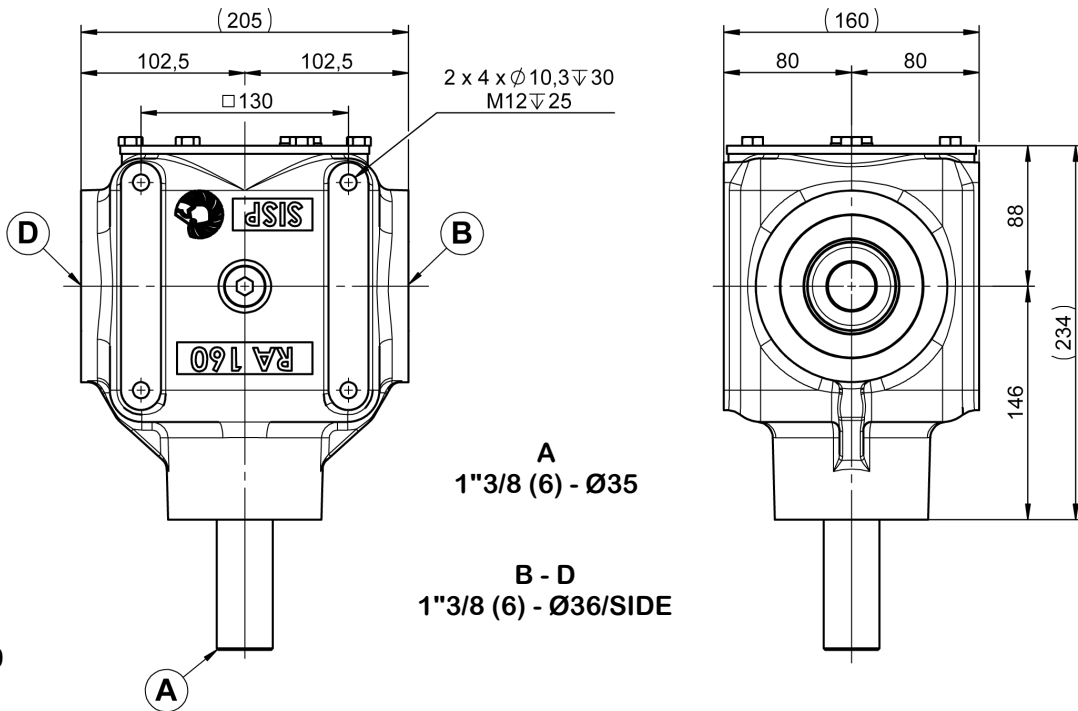

RA160 RENVOI D'ANGLE

RA160 GEARBOX



RAPPORT RATIO	T/MN - RPM	A			B - D	
		CV - HP	KW	NM	T/MN - RPM	NM
1.05/1	540	75	55	953	567	905
1/1.28		63	46	840	422	1070
1/1.47		60	44	796	367	1172
1/1.83		41	30	552	295	1000
1.05/1	1000	128	94	876	1050	836
1/1.28		109	80	781	781	1000
1/1.47		104	76	744	680	1096
1/1.83		72	53	516	546	936

RAPPORT RATIO	T/MN - RPM	B - D			A	
		CV - HP	KW	NM	T/MN - RPM	NM
1/1.05	540	75	55	995	514	1044
1.28/1		102	75	1064	685	840
1.47/1		87	64	1160	792	796
1.83/1		73	54	968	990	532

