

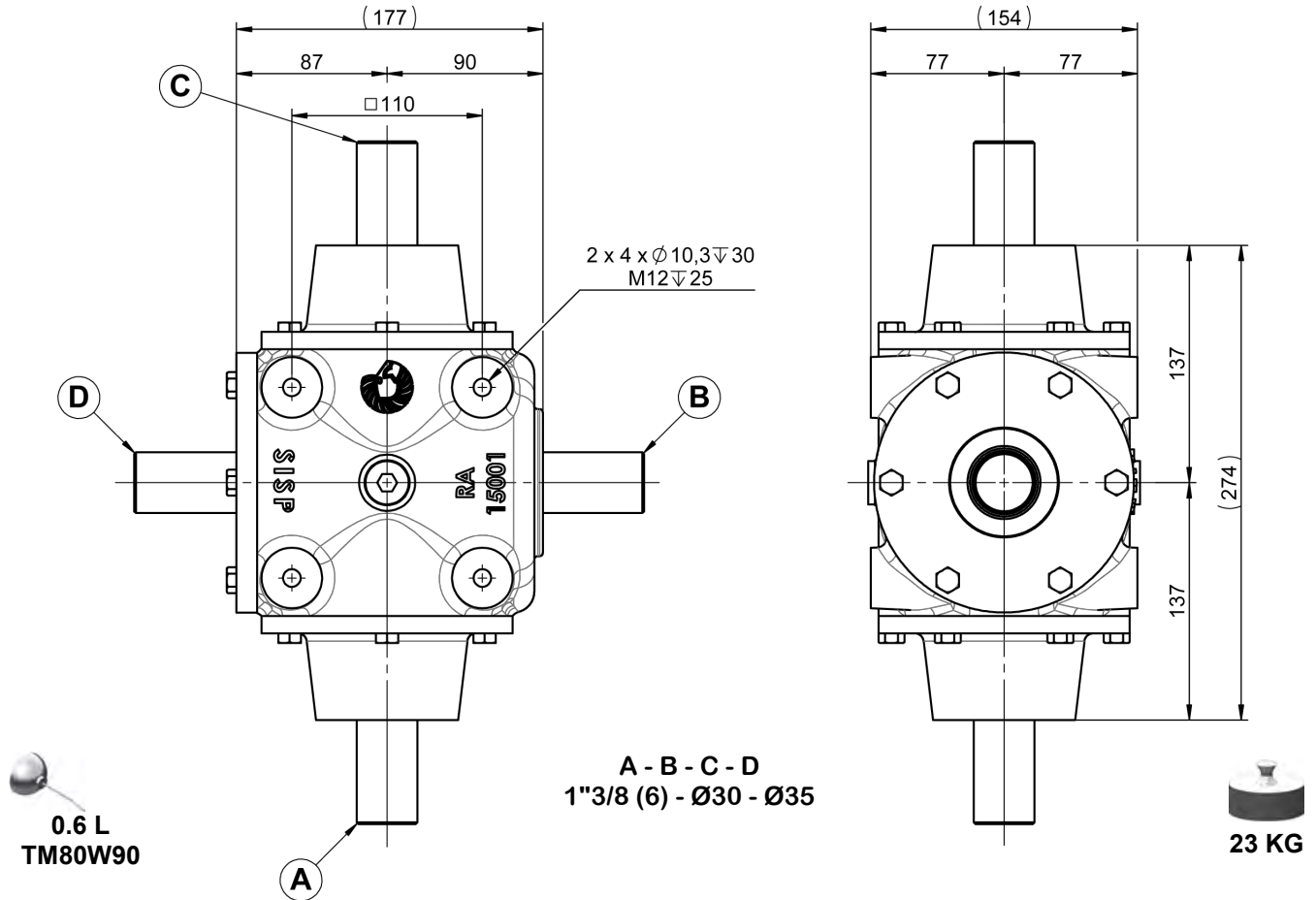

RA150 RENVOI D'ANGLE

RA150 GEARBOX



A - B - C - D
1"3/8 (6) - Ø30 - Ø35

RAPPORT RATIO	T/MN - RPM	A - C			B - D	
		CV - HP	KW	NM	T/MN - RPM	NM
1/1	540	72	53	950	540	950
1/1.5		43	31	556	360	832
1/2		22	16	298	284	596
1/1	1000	123	90	880	1000	880
1/1.5		74	54	520	666	780
1/2		39	29	280	500	564

