

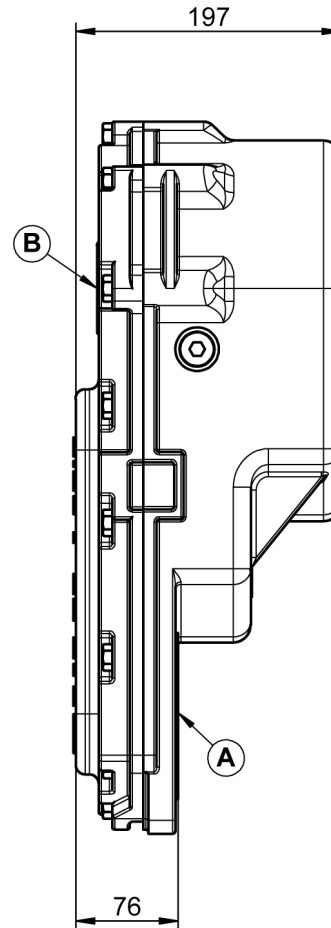

RH316 REDUCTEUR HYDRAULIQUE

RH316 HYDRAULIC REDUCER

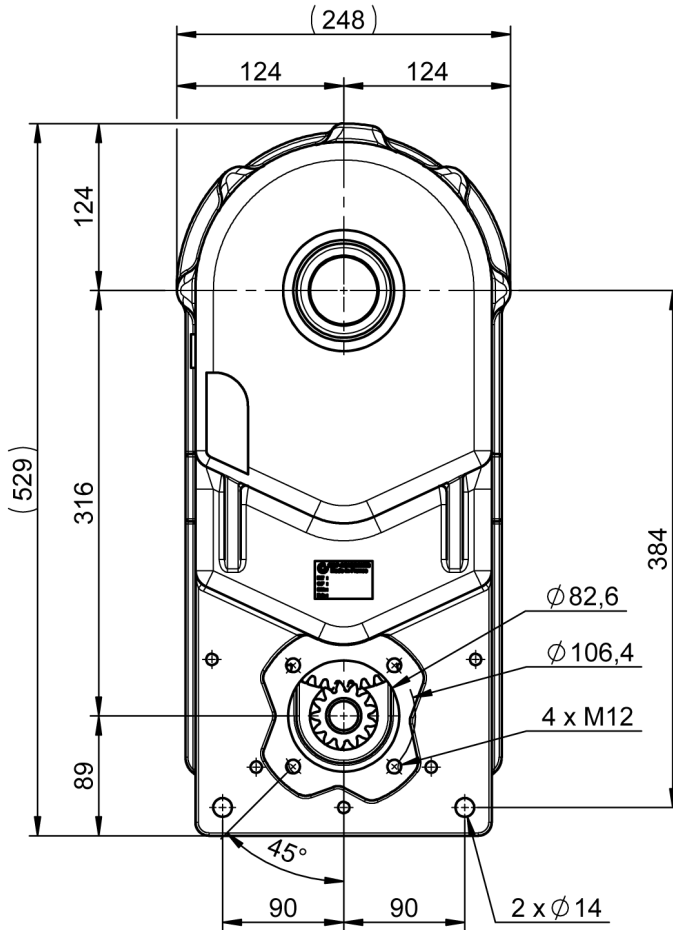

N° P20

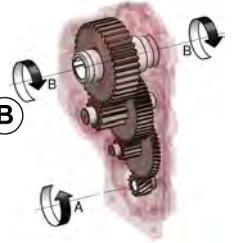

2.5 L
TM80W90

Livré sans huile / Delivered without oil

60 KG

REDUCTEUR / REDUCER								
RAPPORT RATIO	Ø	T/MN - RPM	A CV - HP	KW	NM	Ø	B T/MN - RPM	NM
1/38.5	Ø25 - 1" (6)	540	11	8	144	Ø40	15	5200
1/18.5			20	15	269	Ø50 Ø55		