

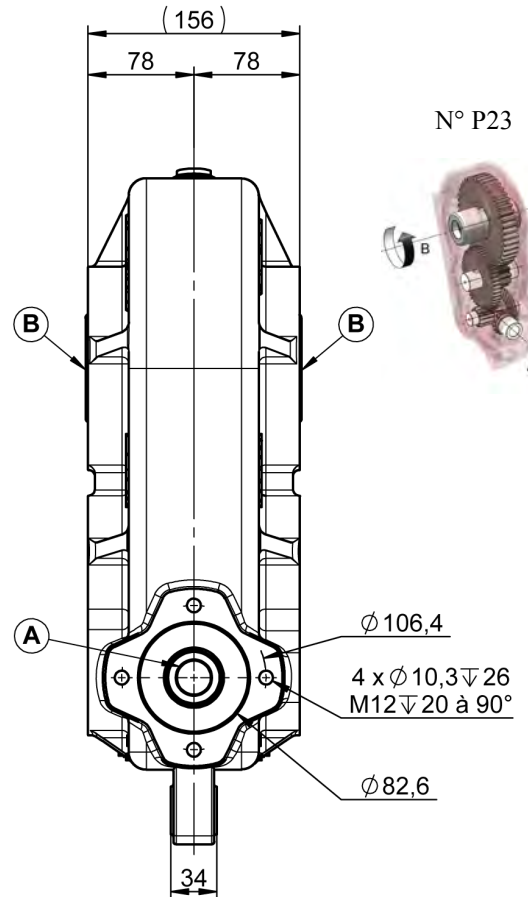

RH232 REDUCTEUR HYDRAULIQUE

RH232 HYDRAULIC REDUCER

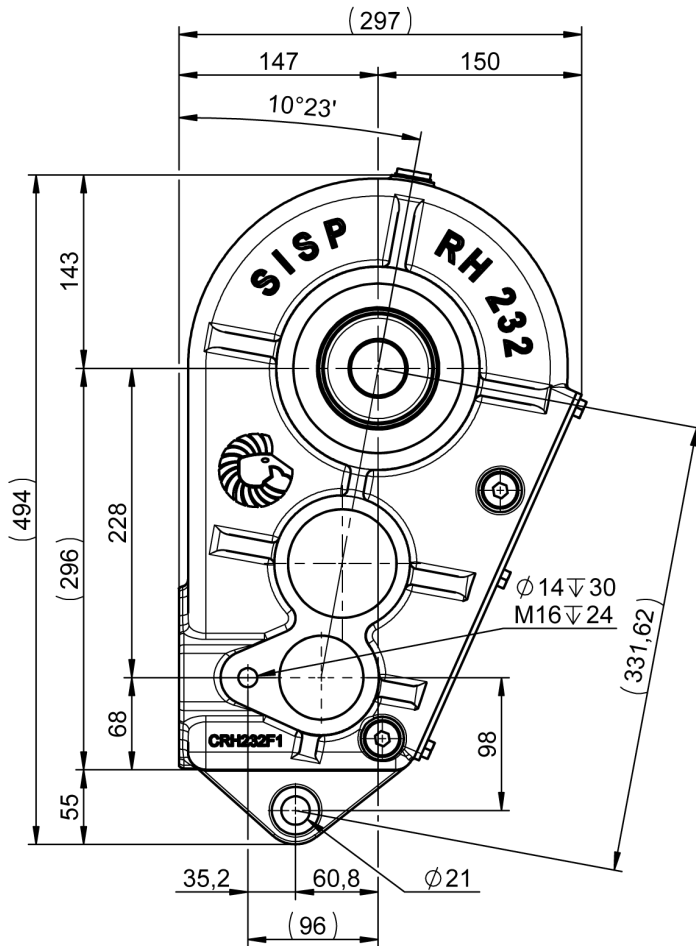

N° P23

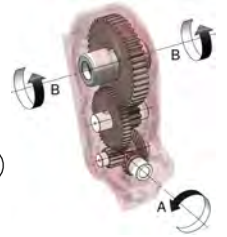

 2.5 L
TM80W90

Option : Voyant d'huile des deux côtés.
Oil indicator on both side.

Trou taraudé pour capteur.
Hole for sensor.

 50 KG

REDUCTEUR / REDUCER								
RAPPORT RATIO	Ø	T/MN - RPM	A CV - HP	KW	NM	Ø	B T/MN - RPM	NM
1/36.8	Ø25 - 1" (6)	540	10.24	7.53	136	Ø35	15	5000
						Ø40		
						Ø45		
						Ø50		
						Ø55		
						Ø60		