

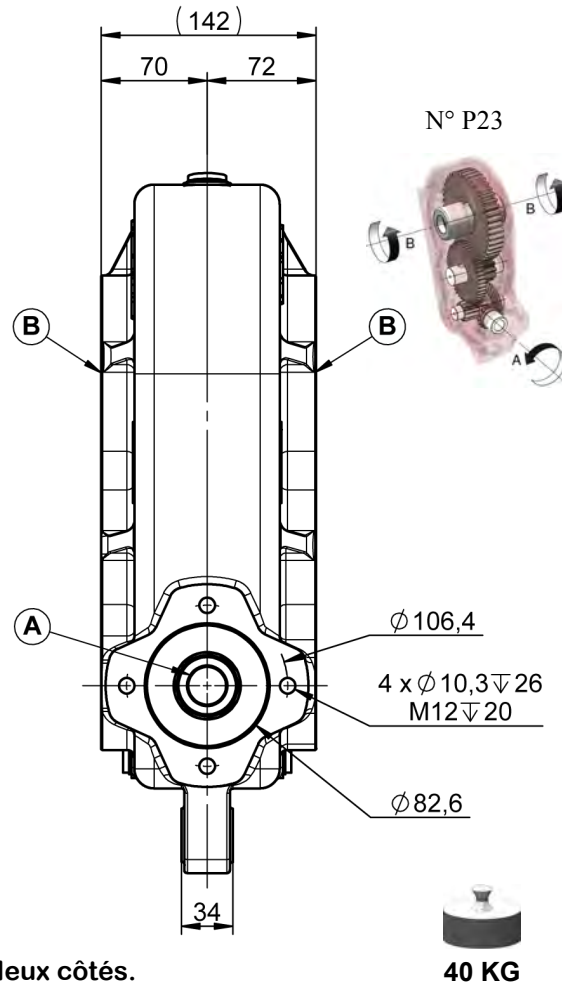

RH209 REDUCTEUR HYDRAULIQUE

RH209 HYDRAULIC REDUCER

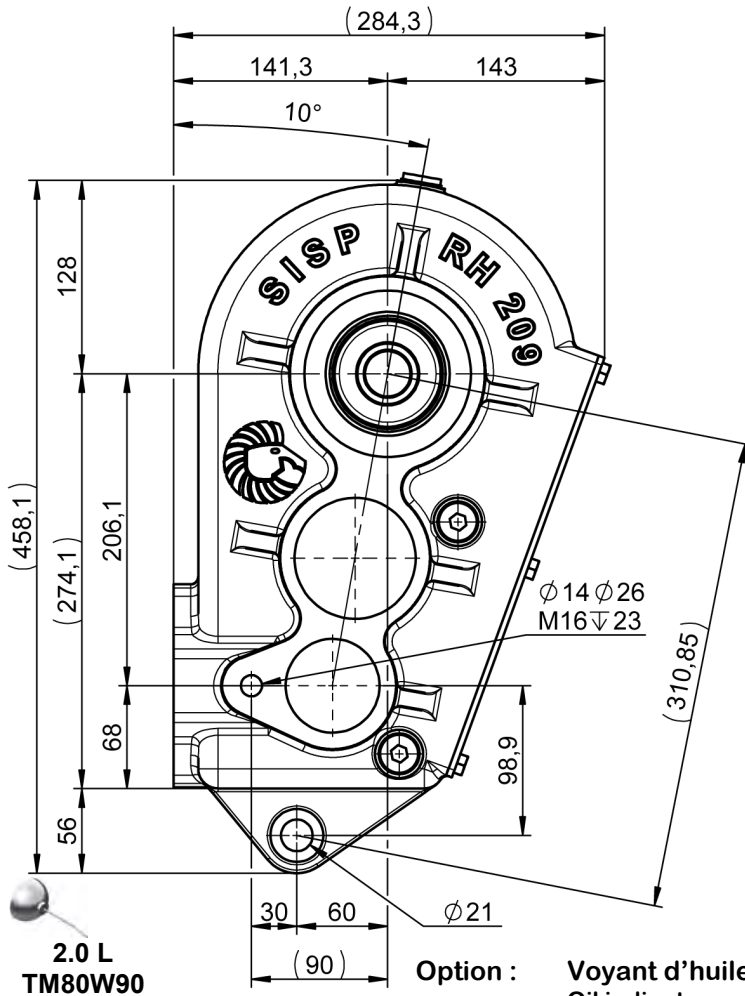

Option : Voyant d'huile des deux côtés.
Oil indicator on both side.

40 KG

REDUCTEUR / REDUCER								
RAPPORT RATIO	Ø	T/MN - RPM	A CV - HP	KW	NM	Ø	B T/MN - RPM	NM
1/30	Ø25 - 1" (6)	540	8.8	6.5	116	Ø30	18	3500
						Ø35		
						Ø40		
						Ø45		
						Ø50		