

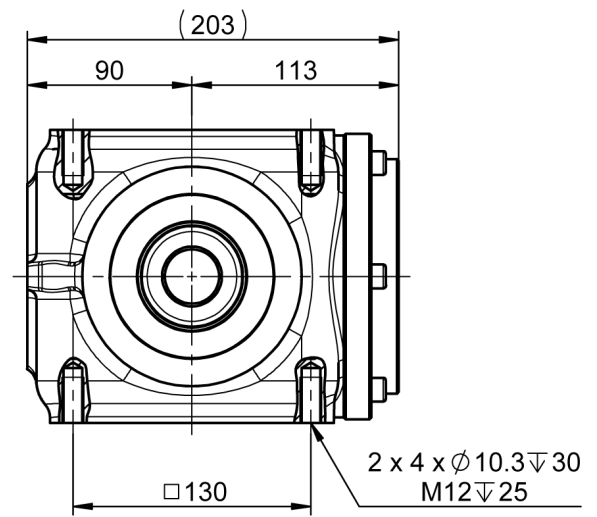

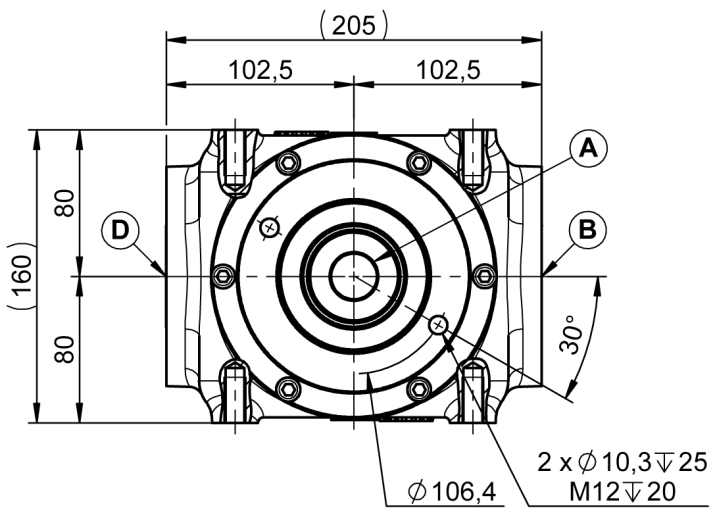

# RAH160 REDUCTEUR HYDRAULIQUE

## RAH160 HYDRAULIC REDUCER



 **0.8 L**  
**TM80W90**

 **21 KG**

REDUCTEUR / REDUCER								
RAPPORT RATIO	$\phi$	T/MN - RPM	A CV - HP	KW	NM	$\phi$	B - D T/MN - RPM	NM
1.05/1	$\phi 25$	540	71	52	950	$\phi 36/P$ by Side F	567	905
						1"3/8 (6) F		

