

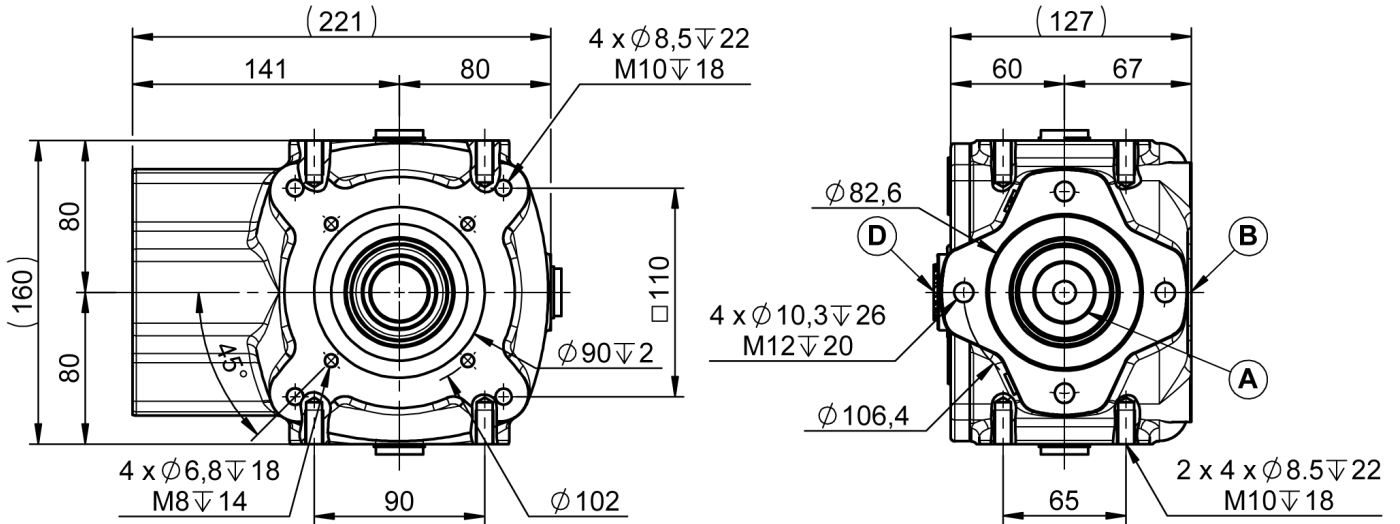

RAH110 REDUCTEUR HYDRAULIQUE

RAH110 HYDRAULIC REDUCER



0.3 L
TM80W90

Option : Version renforcée
Reinforced version

12 KG

REDUCTEUR / REDUCER								
RAPPORT RATIO	ϕ	T/MN - RPM	A CV - HP	KW	NM	ϕ	B - D T/MN - RPM	NM
1/3	$\phi 25$	540	22	16	300	$\phi 30$ F	180	900
						$\phi 35$ F		
						1"3/8 F		
						1"3/8 M x2		
						1"3/4 M x2		

