

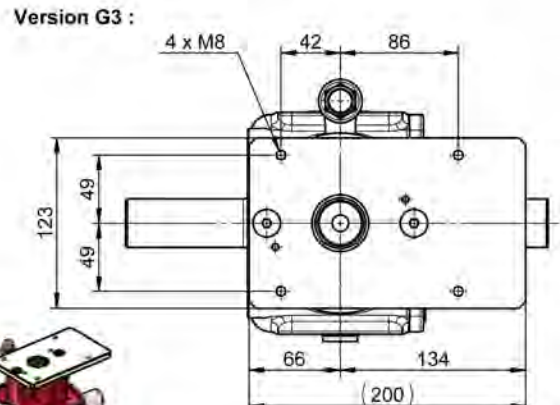

# RAH110 MULTIPLICATEUR

## RAH110 MULTIPLIER G2, G3

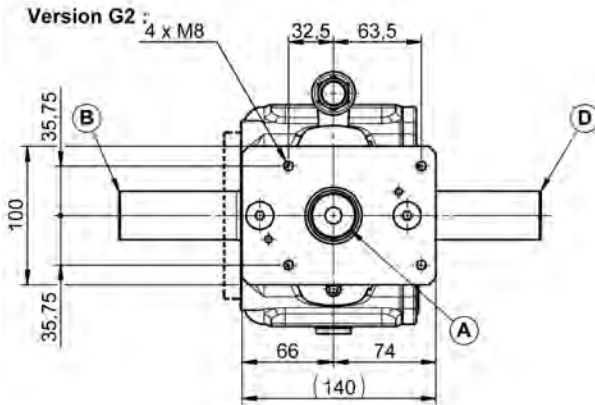
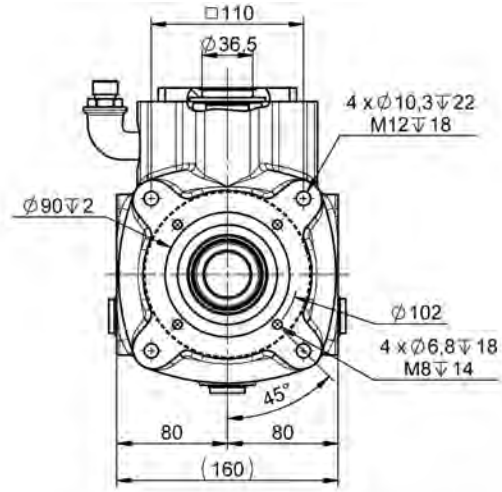
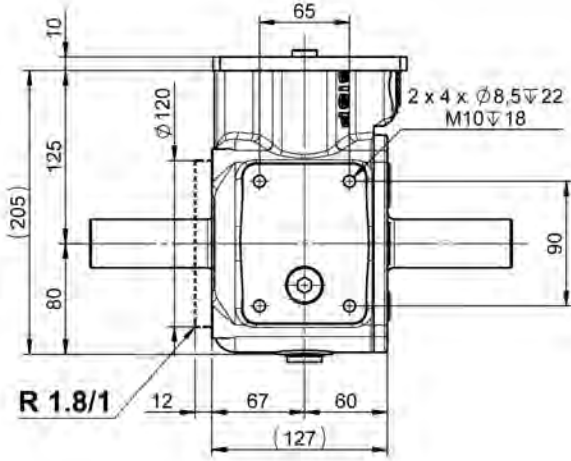

0.32 L  
TM80W90

Boîtier R 1,8/1 +12 mm (139 mm) coté arbre B,  
Gearbox with the ratio R 1,8/1 +12 mm (139 mm) side B shaft,

16 KG

RAPPORT RATIO	Ø	T/MN	B - D CV	KW	NM	Ø	A T/MN	NM
3/1	Ø30 F	1000	65	48	467	Ø35 F (18)	3000	155
	Ø35 F							
1.8/1	1"3/8 F	1000	72	53	520	M1.175 DIN 5482	1810	290
	Ø35 M x2							
	1"3/8 M x2							
1"3/4 M x2								

