

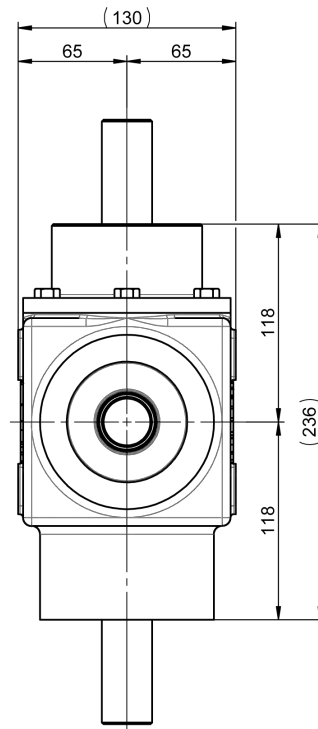

T25 RENVOI D'ANGLE

T25 GEARBOX

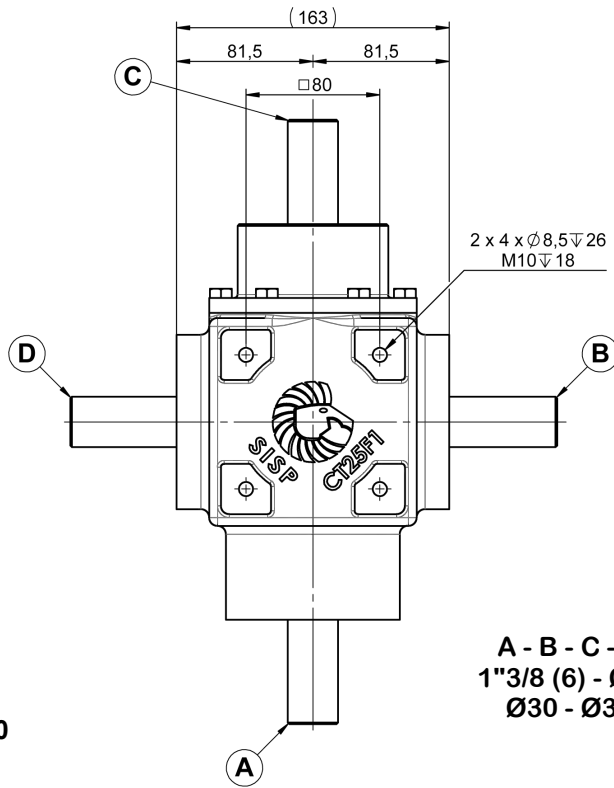

A - B - C - D
1"3/8 (6) - Ø25
Ø30 - Ø35

18 KG

0.4 L
TM80W90

RAPPORT RATIO	T/MN - RPM	A - C			B - D	
		CV - HP	KW	NM	T/MN - RPM	NM
1/1	540	36	26	480	540	480
1/1.21		36	26	480	446	580
1/1.5		21	15.5	276	360	412
1/2		18	13	236	270	472
1/2.5		14	10.3	180	216	452
1.21/1		49	36	536	653	644
1/1	1000	63	46	452	1000	452
1/1.21		52	38	377	824	453
1/1.5		36	26.5	260	666	388
1/2		30	22	222	500	444
1/2.5		24	18	173	400	432
1.21/1		55	40	500	1214	416

