

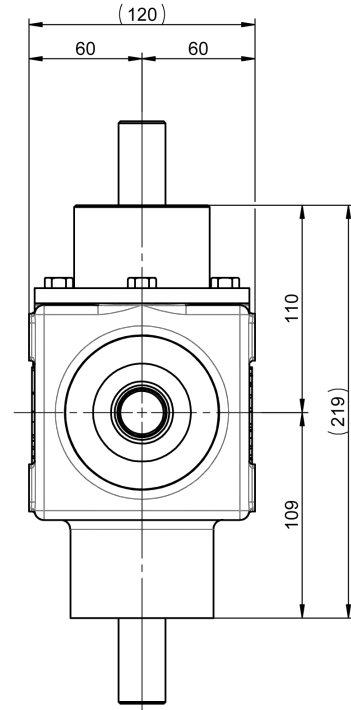

T10 RENVOI D'ANGLE

T10 GEARBOX

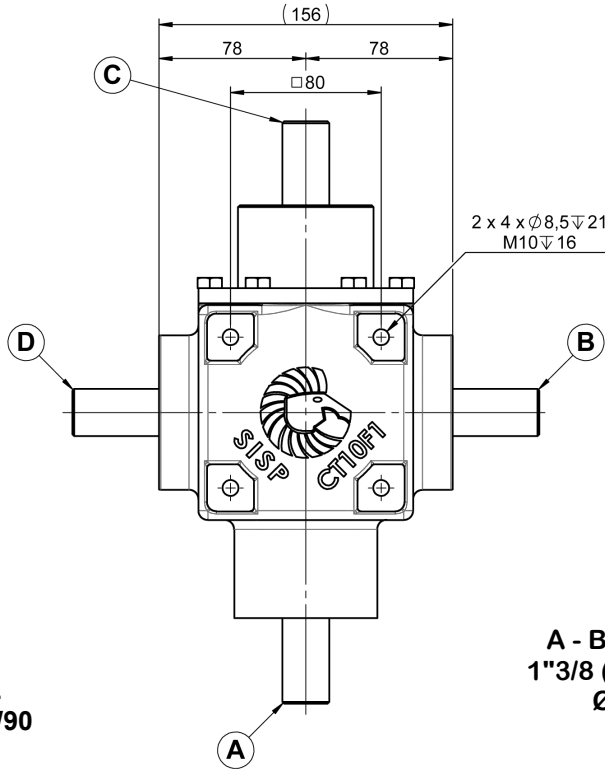

0.3 L
TM80W90

A - B - C - D
1"3/8 (6) - Ø25
Ø30

11 KG

RAPPORT RATIO	T/MN - RPM	A - C			B - D	
		CV - HP	KW	NM	T/MN - RPM	NM
1/1	540	22	16	300	540	300
1/1.5		20	15	272	360	408
1/1.9		15	11	200	284	380
1/2.77		7.5	5.6	101	195	277
1.5/1		32	23	420	810	280
1/1	1000	38	28	272	1000	272
1.5/1		56	41	402	1500	268
1/1.9		26	19	190	526	360
1/2.77		13.3	9.8	96	361	264
1/1.5		35	25	253	666	380

