

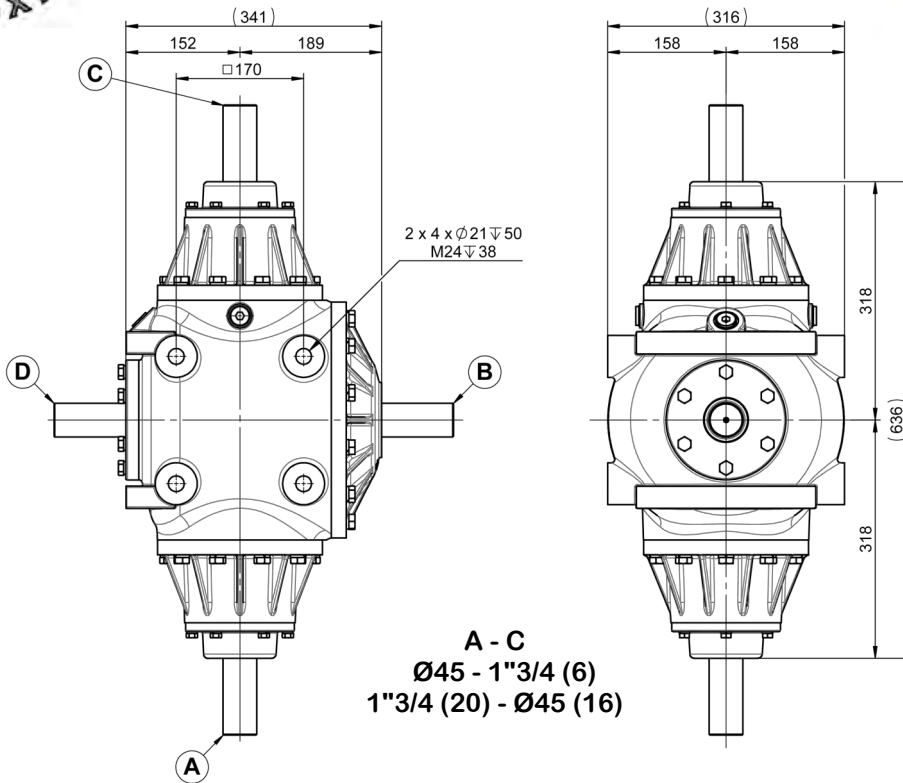

# RA320 RENVOI D'ANGLE

## RA320 GEARBOX



RAPPORT RATIO	T/MN - RPM	A - C			B - D	
		CV - HP	KW	NM	T/MN - RPM	NM
1/1	540	252	185	3340	540	3340
1.25/1		225	166	2991	432	3740
1/1.85		194	143	2572	292	4748
1/2.4		180	133	2392	225	5740
1/1	1000	424	311	3036	1000	3036
1.25/1		380	280	2726	800	3406
1/1.85		330	242	2360	540	4368
1/2.4		310	228	2224	416	5336

RAPPORT RATIO	T/MN - RPM	B - D			A - C	
		CV - HP	KW	NM	T/MN - RPM	NM
1.25/1	540	363	267	3854	675	3083
1.85/1		361	266	4780	999	2588
2.41/1		438	322	5820	1296	2424

