

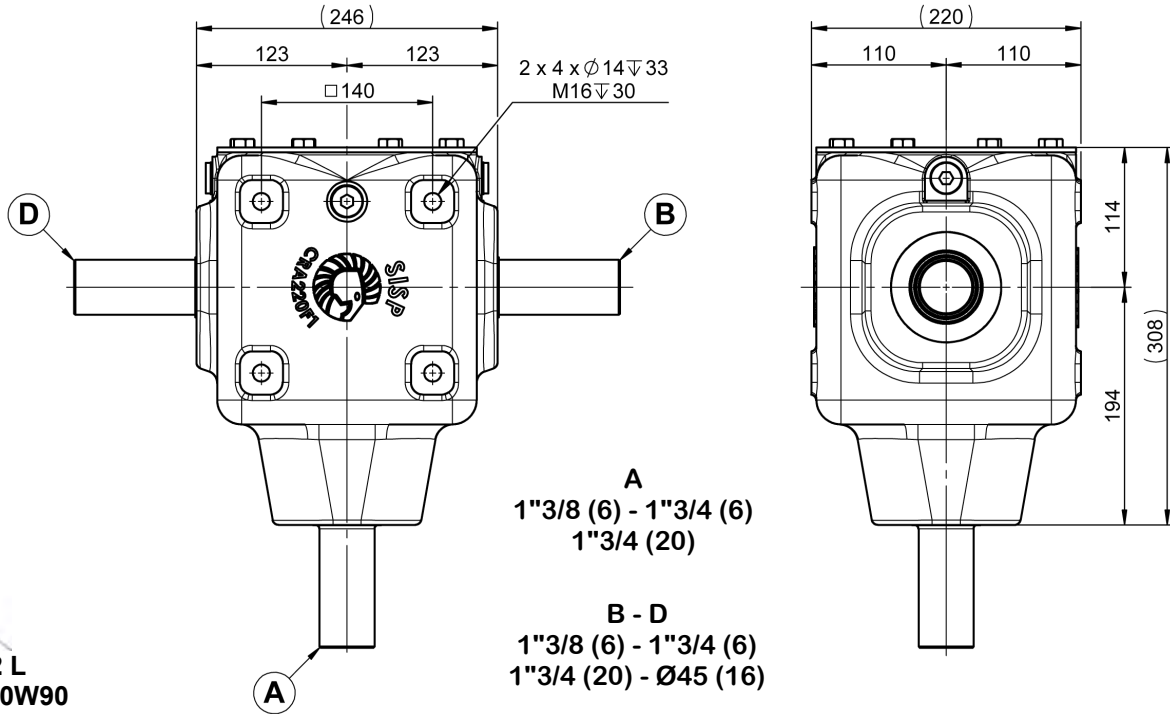

RA220 RENVOI D'ANGLE

RA220 GEARBOX

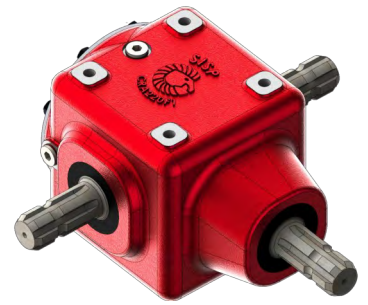

ENTREE A VERSION STANDARD / INPUT A STANDARD VERSION

RAPPORT RATIO	T/MN - RPM	A			B - D	
		CV - HP	KW	NM	T/MN - RPM	NM
1/1	540	156	115	2070	540	2070
1/1.28		137	100	1820	422	2330
1/1.54		124	91	1650	350	2528
1/1	1000	266	196	1910	1000	1910
1/1.28		235	173	1684	781	2156
1/1.54		212	156	1528	650	2344

ENTREE A VERSION RENFORCEE / INPUT A REINFORCED VERSION

RAPPORT RATIO	T/MN - RPM	A			B - D	
		CV - HP	KW	NM	T/MN - RPM	NM
1/1.54	540	168	124	2232	350	3412
1/1.54	1000	288	212	2064	650	3156

