

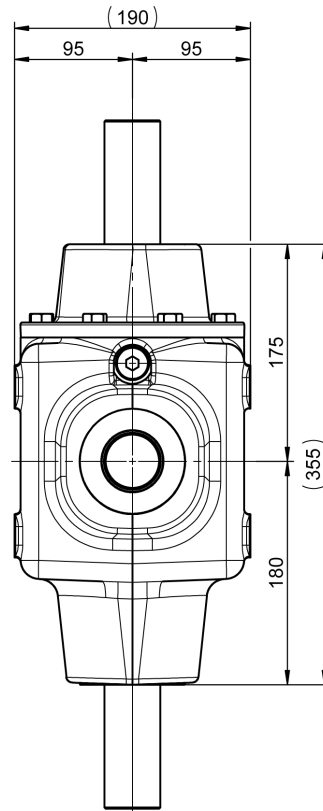

RA190 RENVOI D'ANGLE

RA190 GEARBOX

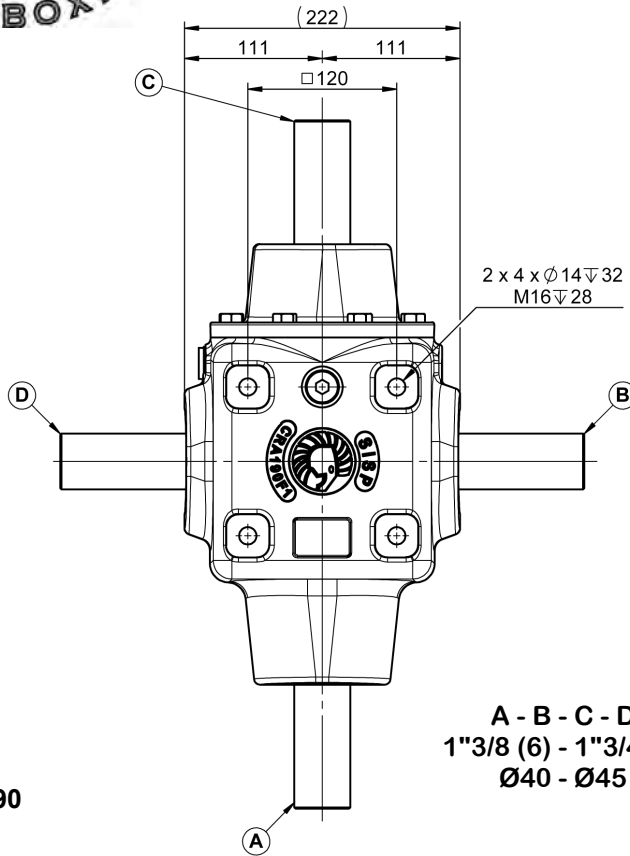

A - B - C - D
 1"3/8 (6) - 1"3/4 (6)
 Ø40 - Ø45

1.3 L
 TM80W90

42 KG

RAPPORT RATIO	T/MN - RPM	A - C			B - D	
		CV - HP	KW	NM	T/MN - RPM	NM
1/1	540	128	94	1696	540	1696
1/1.12		117	86	1552	486	1720
1/1.28		104	76	1384	420	1768
1/1.35		103	76	1364	399	1840
1/1.5		80	59	1068	360	1600
1/1.83		69	51	916	295	1664
1/1	1000	218	160	1560	1000	1560
1/1.12		199	146	1428	900	1584
1/1.28		178	131	1280	778	1636
1/1.35		176	130	1264	739	1704
1/1.5		138	102	992	666	1488
1/1.83		119	87	852	545	1552

