

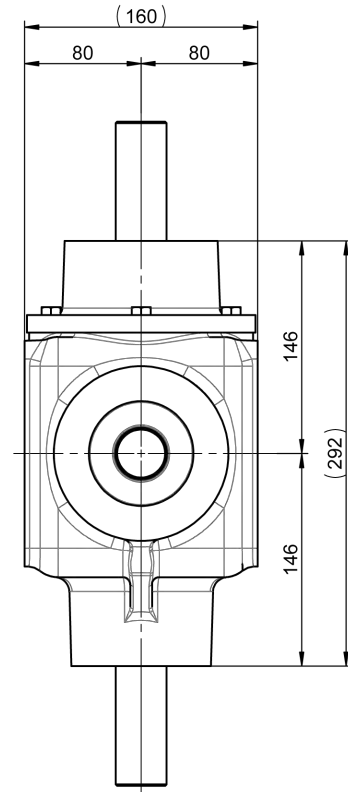

RA160 RENVOI D'ANGLE

RA160 GEARBOX

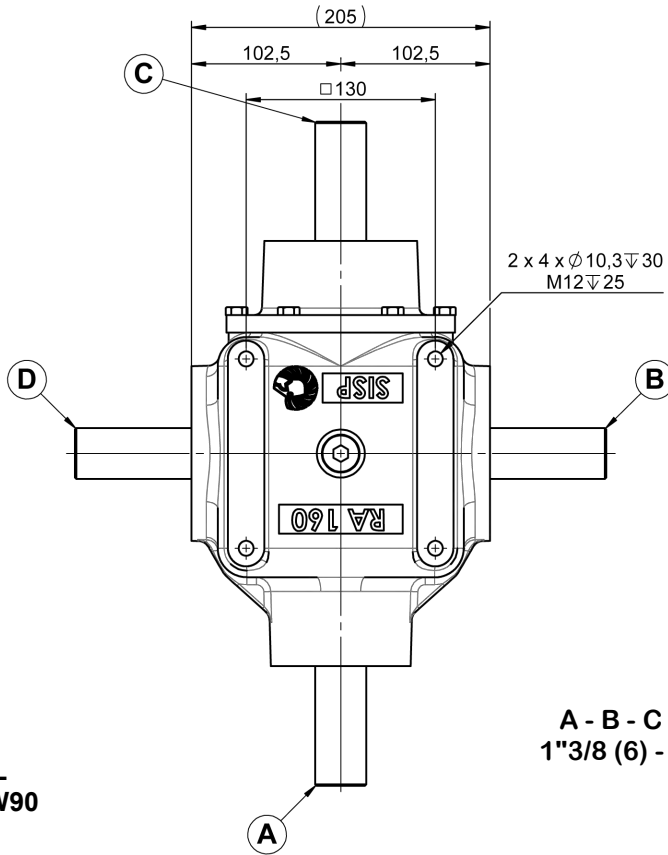

A - B - C - D
1"3/8 (6) - $\varnothing 35$

0.8 L
TM80W90

28 KG

RAPPORT RATIO	T/MN - RPM	A - C			B - D	
		CV - HP	KW	NM	T/MN - RPM	NM
1/1	540	89	65	1176	540	1176
1/1.28		63	46	840	422	1070
1/1.47		60	44	796	367	1172
1/1.83		41	30	552	295	1000
1/1	1000	152	111	1088	1000	1088
1/1.28		109	80	781	781	1000
1/1.47		104	76	744	680	1096
1/1.83		72	54	516	546	936

