



# C5 RENVOI D'ANGLE

## C5 GEARBOX



Option: Roue libre / Overrunning clutch

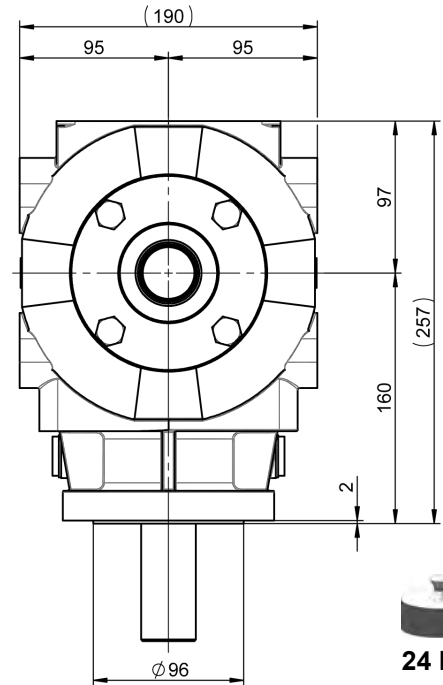
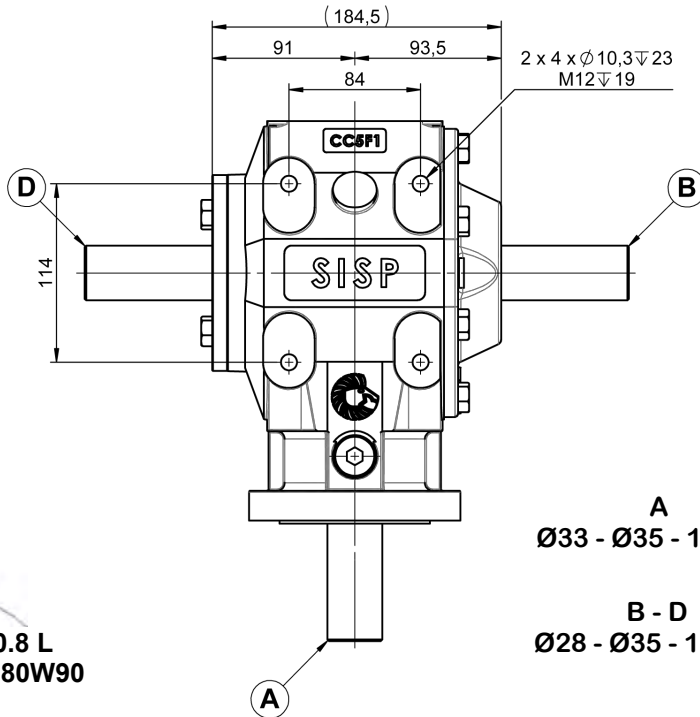

**A**  
Ø33 - Ø35 - 1"3/8 (6)

**B - D**  
Ø28 - Ø35 - 1"3/8 (6)

24 KG

0.8 L  
TM80W90

RAPPORT RATIO	T/MN - RPM	A			B - D	
		CV - HP	KW	NM	T/MN - RPM	NM
1/3	540	40	29	540	180	1620
1/4		30	22	396	135	1592
1/4.5		20	15	268	120	1208
1/3	1000	71	52	508	333	1524
1/4		54	40	384	250	1540
1/4.5		36	26	256	222	1160

RAPPORT RATIO	T/MN - RPM	B - D			A	
		CV - HP	KW	NM	T/MN - RPM	NM
3/1	540	84	61	1612	1620	368
4/1		80	59	1060	2160	265
4.5/1		75	55	994	2430	221

