

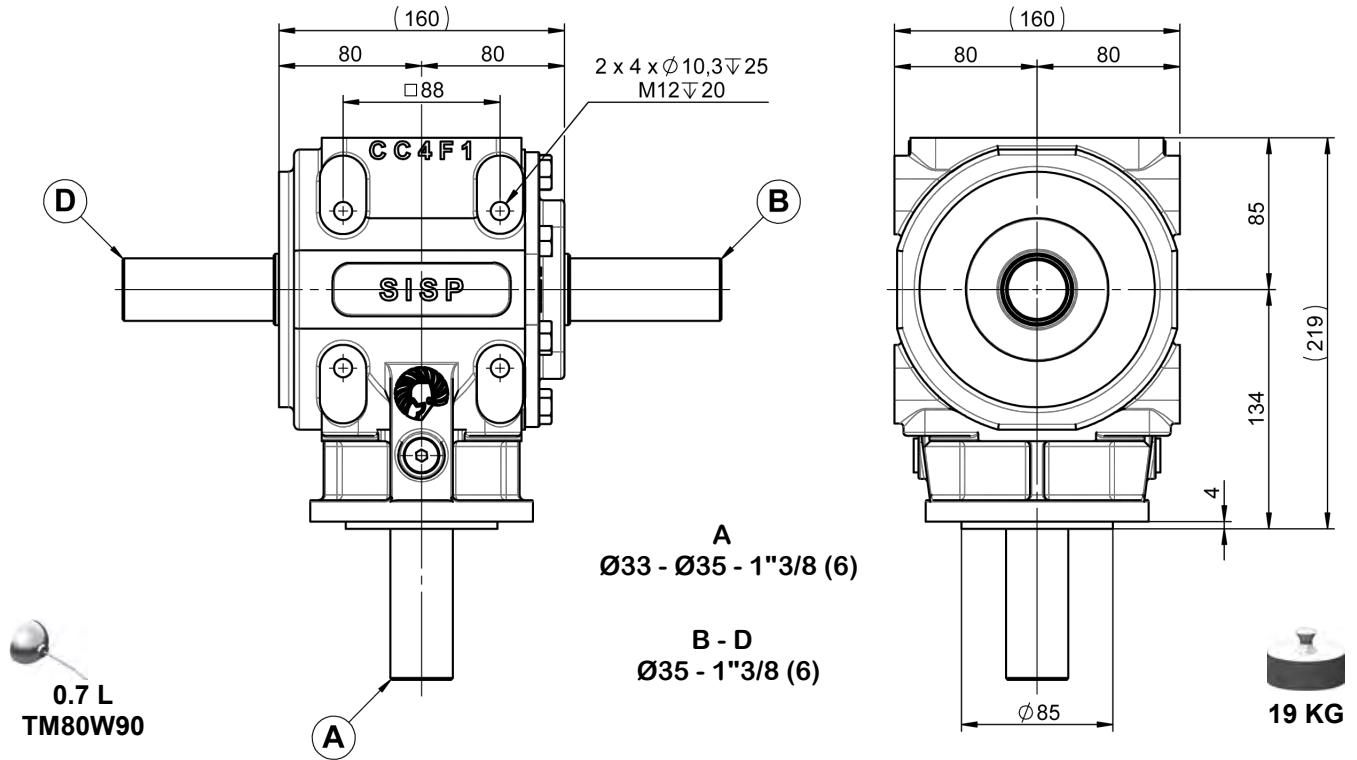

C4 RENVOI D'ANGLE

C4 GEARBOX



RAPPORT RATIO	T/MN - RPM	A			B - D	
		CV - HP	KW	NM	T/MN - RPM	NM
1/3	540	22	16	300	180	900
1/3	1000	40	30	286	333	860

RAPPORT RATIO	T/MN - RPM	B - D			A	
		CV - HP	KW	NM	T/MN - RPM	NM
3/1	540	64	47	852	1620	284

