



C2 RENVOI D'ANGLE

C2 GEARBOX



Option: Roue libre / Overrunning clutch

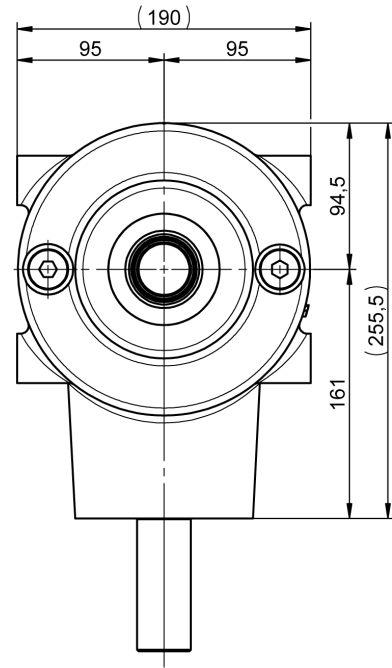
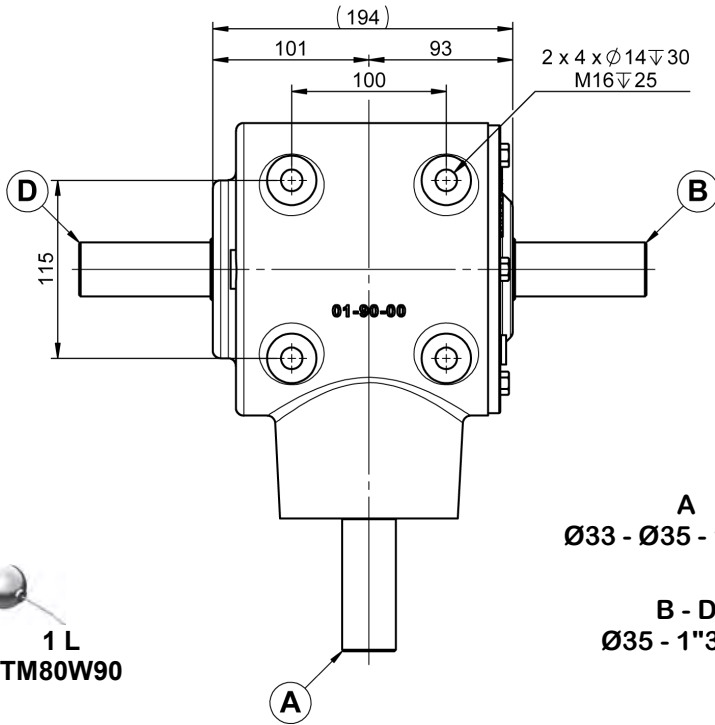

A
Ø33 - Ø35 - 1"3/8 (6)

B - D
Ø35 - 1"3/8 (6)



RAPPORT RATIO	T/MN - RPM	A			B - D	
		CV - HP	KW	NM	T/MN - RPM	NM
1/2.07	540	39	29	518	260	1072
1/3		35	26	469	180	1408
1/4.5		20	15	268	120	1208
1/2.07	1000	68	50	486	481	1006
1/3		62	46	444	333	1328
1/4.5		36	26	256	222	1160

RAPPORT RATIO	T/MN - RPM	B - D			A	
		CV - HP	KW	NM	T/MN - RPM	NM
3/1	540	88	65	1164	1620	388
2.07/1		68	50	894	1122	432
4.5/1		75	55	994	2430	221

