



C1 RENVOI D'ANGLE

C1 GEARBOX



Option: Roue libre / Overrunning clutch

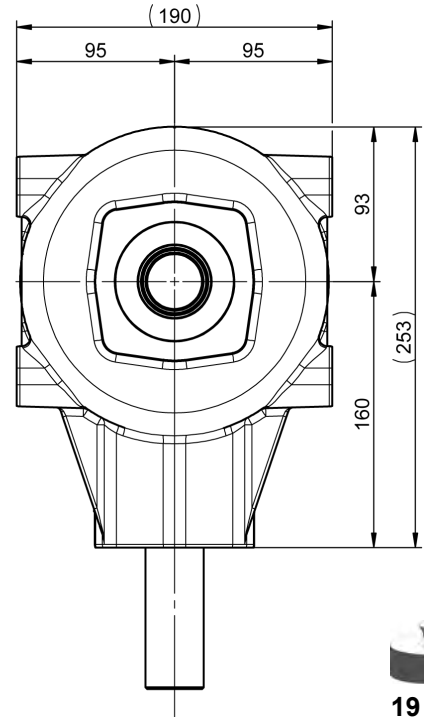
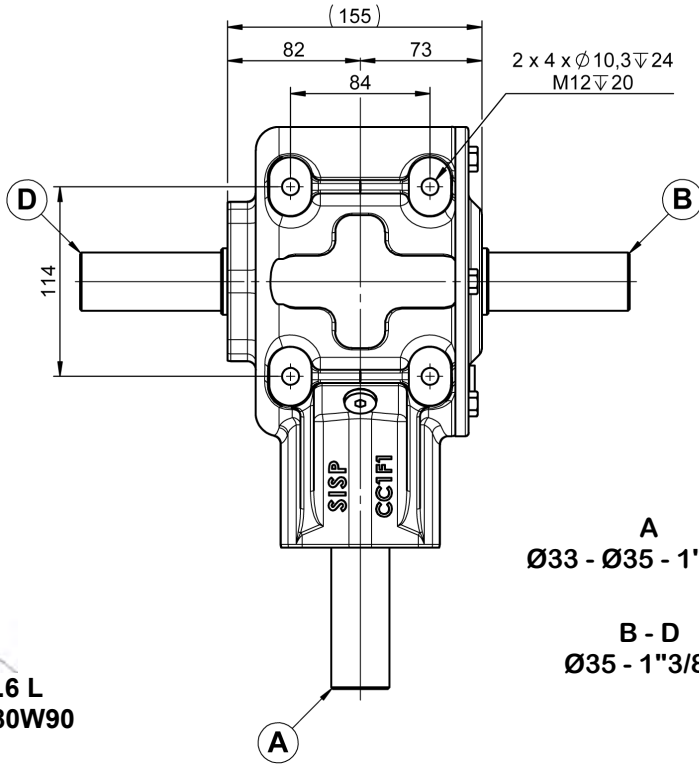

A
Ø33 - Ø35 - 1"3/8 (6)

B - D
Ø35 - 1"3/8 (6)

0.6 L
TM80W90

19 KG

RAPPOR RATIO	T/MN - RPM	A			B - D	
		CV - HP	KW	NM	T/MN - RPM	NM
1/3	540	35	26	469	180	1408
1/4		23	17	305	135	1219
1/4.5		20	15	268	120	1208
1/3	1000	62	46	444	333	1328
1/4		40	29	288	250	1160
1/4.5		36	26	256	222	1160

RAPPOR RATIO	T/MN - RPM	B - D			A	
		CV - HP	KW	NM	T/MN - RPM	NM
3/1	540	88	65	1160	1620	388
4/1		80	59	1060	2160	265
4.5/1		75	55	994	2430	221

